

 **ARISTON**

OUR IDEAS. YOUR HOME.



Cooking Collection





"The designer's contribution is to go beyond your expectations achieving an excellent and unique result"

Makio Hasuike

The minimalist, Italian design and high specification of the Luce collection will add a beautiful contemporary touch to any kitchen.

With performance that matches up to its great looks

– Luce is about far more than style.



When you find something you love and trust, stick with it - I have used Ariston for 10 years now, both in my cooking school at Fenix and in my own home - I trust Ariston

Gary Mehigan
Celebrity Chef





Contents

Proud Partners
of Masterchef
Australia

Ovens	4
Compacts	11
Large ovens	14
Hobs	15
Uprights	20
Rangehoods	22
Dishwashers	24
Specifications	26



Ariston offers a

5 Year Warranty
on all cooking appliances

OPENSOURCE



MORE ROOM FOR FLEXIBILITY

With the same external dimensions as a 60cm oven, and a standard built-in space, the Openspace oven offers 20% extra capacity with its 81 litres of greater versatility.

It offers the option of cooking on 4 shelves at the same time or cooking large quantities which would not necessarily be possible in a traditional oven.

PROGRAMS & FUNCTIONS

Thanks to the Extra Large Space, Openspace offers 10 cooking functions: 6 of which are universal and suitable for any type of cooking, while the remaining 4 are automatic programs which can be used to achieve perfect results for any recipe.



Bread Program

The aroma of hot oven-baked bread is an experience that evokes the flavours of bygone days. Today, you can experience this directly at home thanks to the new Bread function. The oven sets the various cooking phases by establishing time and temperature with an excellent result every time.



Pastries Program

This cycle is set for the cooking of traditional cakes, pasteries and pies.



Pizza Program

It is now possible to cook a pizza at home with the same results as using a wood-fired oven. Perfect internal and external cooking in only 30 minutes.



Meat Program

This cycle is set for cooking each kind of meat in the most appropriate way. This automatic program consists of 3 phases: external colouring, internal cooking and "resting" – where the temperature decreases slowly and the combined action of the heating elements and the cooling fan control the humidity. The level of cooking can be regulated according to all different tastes, with the possibility to change duration to have the "well-done", "medium" or "rare" result.



Divide The Space To Multiply It.

Openspace's most innovative feature is the insulating divider that separates the whole Extra Large cavity into 2 different-sized spaces:

SMALL SPACE – Approximately 20 litres net, equipped with a revolutionary Fast Cooking system and grill function

MAIN SPACE – Approximately 48 litres net, with its fan cooking function that allow the preparation of any kind of dish.

The 2 spaces, Small & Main, offer unimaginable versatility. They can be used simultaneously to prepare a complete dinner in a shorter time, or separately, just using the space required for your particular needs.

When they are used together, cooking temperatures can be regulated between 50°C and 250°C with a difference of as much as 100°C between the 2 compartments. This makes it possible to cook very different dishes, also safe in the knowledge that smells and flavours will not mix.

Openspace is the only one on the market to offer the maximum in flexibility.



UNIVERSAL PROGRAMS:



Multilevel Cooking

All heating elements and the fan are activated. With this function it's possible to cook simultaneously on up to 4 levels at the same time.



Gratin

The top heating element and the fan are activated. This helps to prevent food from burning or drying out by heating through while allowing a nice browned crust



Barbeque

The top heating element is activated. The high and direct temperature of the grill is perfect for food that requires a high surface temperature.



Low Temperature

3 low temperature programs:
40°C - Defrost, raising, yoghurt
65°C - Reheat, warming
90°C - Low temp cooking

OS 99 DPIX



60cm OpenSpace Extra Large Oven

- 81 Lt capacity: 20% increase in internal space
- 4 ovens in 1:
 - a) 4 simultaneously cooking in the EXTRA LARGE oven (81 Lt)
 - b) Cooking in the upper SMALL oven (20 Lt)
 - c) Cooking in the lower MAIN oven (48 Lt)
 - d) Simultaneously cooking in the upper SMALL oven & lower MAIN oven (20 + 48 Lt)
- 10 cooking functions in the EXTRA LARGE oven: 4 automatic programs + 6 universal functions.
- 2 functions in the SMALL oven: Fast Cooking & Grill
- Fan cooking in main oven
- Fast Clean – Pyrolytic self-cleaning function
- Integrated ventilation system
- 3 oven glass doors
- Glass inner door
- Divider
- Grey cavity
- 2 halogen lights
- Electronic regulation timing and temperature
- Quick guide provided
- Anti-touch Stainless Steel – Easy to Clean



Largest European 60cm
Oven In The Market

MADE IN ITALY

OPENSOURCE

OK897EL C X AUS



60cm Luce OpenSpace multifunction oven

- 12 cooking functions including: Multilevel, Barbeque, Gratin, Pizza, Low temperature (meat, fish, vegetables), Fast cooking, Eco, Beef, Bread, Cakes
- 81L Gross capacity
- Self-cleaning catalytic liners
- Electronic knobs and touch control with digital display
- Triple glazed door with full glass inner
- Fully programmable clock and timer
- Stylish black glass and stainless steel design



As Used on Masterchef

MADE IN ITALY

FK898 PX AUS



60cm Luce multifunction oven

- 10 Cooking functions including: Multilevel, Barbeque, Gratin, Pizza, Pastries, Low temperature, Fast cooking, Eco, Bread, Cakes
- 66L Gross capacity
- Pyrolytic self-cleaning function - 3 options
- Electronic knobs and touch control with digital display
- Triple glazed door with full glass inner
- Fully programmable clock and timer
- Telescopic rails
- Stylish black glass and stainless steel design

MADE IN ITALY

LUCE



HD COOKING:

Distributing constant and even heat to every corner of the oven, Dual Flow eliminates cooking hotspots – helping you create beautiful, evenly cooked food.

What's more, our Luce ovens have intelligent controls that retain heat and maintain a stable cooking temperature. The result is perfect puddings and soufflés that always rise to the occasion.

With Luce's inspired features, you'll have the tools and precision you're after to have the ultimate HD cooking experience – and produce faultless dishes, without fail.



FAST CLEAN

Fast Clean is an automatic self-cleaning cycle, which uses a 500°C pyrolysis process to destroy any cooking grease or sugar residues left on the inner walls. The process is completely safe and has a power consumption of less than 2.8 kW: less than the cost of an espresso! Fast Clean ovens have cool touch doors, an automatic door lock and a forced ventilation system that ensures perfect heat insulation.



LUCE



DUAL FLOW

Enjoy perfect evenly cooked food with Luce's Dual Flow system which eliminates cooking hotspots throughout the oven.



HD COOKING

The perfect cooking solution, time after time

It's no secret that the key to sublime food is precision. With Luce's High Definition cooking technologies you'll have unprecedented control over everything you cook.

Luce's exclusive Dual Flow technology gives you the power to cook faster and precisely – while using less energy. With intelligence and beautiful design like this in your kitchen, you're guaranteed to deliver perfect results, every time.

ECO TECH

Eco Tech energy efficiency. One day all kitchens will work this way...

A beautiful, high performing kitchen just isn't enough for the 21st century. The modern kitchen also needs to be designed around energy efficiency – which is where Luce comes into its own.

Not only are Luce products designed to deliver outstanding performance – they also achieve this with minimum energy use. Our patented High Definition cooking technology is just one of the features that helps you save time, money – and energy.

So if efficiency and results matter to you, think Luce.

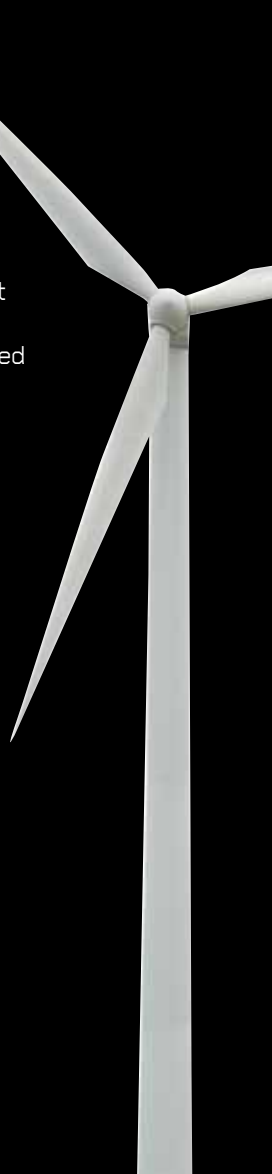



FK737 C X AUS



60cm Luce Multifunction Oven



- 6 cooking functions: Traditional, Multi-Level, Pizza, Pastries, Grill, Gratin
- Self-cleaning catalytic liners
- Rotisserie
- Integrated ventilation system
- 2 oven glass doors
- Glass inner door
- Fully programmable clock and timer
- Anti-touch stainless steel
- 66lt gross oven capacity

MADE IN ITALY

FK617 X AUS



60cm Luce Multifunction Oven



- 6 cooking functions: Traditional, Multi-Level, Pizza, Pastries, Grill, Gratin
- Integrated ventilation system
- 2 oven glass doors
- Glass inner door
- Minute Minder
- Anti-touch stainless steel
- 66lt gross oven capacity

MADE IN ITALY

45^{cm} Collection

LUCE



Perfectly aligned handles, control panels and matching aesthetic ensure that Luce co-ordinates across the range to complement your kitchen in beautiful style.

Luce's sleek 45cm compact range sit together perfectly so they can be installed in any configuration. Choose from microwaves, a steam oven or a built-in coffee machine and create the ultimate style statement.



MWKA424X



45cm Compact Combo Microwave / Oven

- 40L capacity
- 1000W
- 5 Functions including: Microwave, Grill, Fan, Microwave + fan, Microwave + grill
- Auto oven functions including: Drinks, Pasta, Frozen foods, Precooked, Pizza, Fast heating, Plate Warming, Defrost, Cooking
- Electronic knobs and touch control with digital display
- 10 Power levels
- 36mm Turntable
- Electronic timer with end cooking signal
- Stylish black glass and stainless steel design

MADE IN ITALY

MWKA221X



Built-in Microwave

- 24L capacity
- 900W
- 5 Power levels
- Knob and button control
- 30mm Turntable
- Warm plate / Defrost options
- Stylish black glass design

MADE IN ITALY



The fast, healthy and convenient way of cooking that seals valuable vitamins and minerals into food. With a choice of automatic cooking and defrost programmes it is simple to use too.



STEAM OVEN

Healthy eating is a priority to every Australian family.

Steam cooking is fast becoming the most popular way to produce a tasty, easy and most importantly healthy meal. Steaming food retains its nutritional value better than any other way of cooking. The colours, flavours and aromas are maintained in steamed foods.

The Ariston steamer has 7 Automatic functions as well as a universal steam function making the unit easy to use and versatile.



MSKA103X

45cm Compact built-in steam oven

- 23L Net capacity
- 2 Steam functions: Steam cooking, Defrost
- Electronic knobs and touch control with digital display
- Preselected temperatures
- Stylish black glass and stainless steel design

MCKA103X

45cm Compact built-in coffee machine

- 3 Functions including: Coffee, Steam, Hot water
- 3 Coffee types including: Short, Normal, Long
- 1.8L Water reservoir and 300gm bean container
- 15 bar pump pressure
- Built-in coffee grind regulator
- Electronic knobs and touch control with digital display
- Stylish black glass and stainless steel design



Make the perfect latte, cappuccino or espresso at the touch of a button. Can be used with either coffee beans or ground coffee and will even store your favourite settings.



MADE IN ITALY



DN 62 X



60cm Experience Line Double Oven

- Main Oven - 6 cooking functions: Traditional, Fan Forced, Fan Assist, Fan Grill, Full Grill, Half Grill
- Second Oven - 2 cooking functions: Full Grill, Half Grill
- Integrated ventilation system
- 3 oven glass doors
- Glass inner door
- Digital Timer
- Self-cleaning catalytic liners
- Gross oven capacity: 78 Lt (Main oven), 37 Lt (Second oven)



MB 91 IX



90cm Maxi Oven

- 7 cooking functions: Traditional, Lower Heating Element, Upper Heating Element, Grill, Gratin, Pastries & Multi-level.
- Integrated ventilation system
- 3 oven glass doors
- Rotisserie
- Electronic Start / End of cooking Timer
- 90 Lt gross oven capacity

CONTROL

The double crown double regulation allows you to cook better and in less time, achieving maximum flexibility and efficiency. The flame can be regulated separately on each crown. It is now possible to achieve the most delicate heat for gentle cooking to the most powerful flames where an intense heat is required.



Our unique HD technologies are designed with the discerning cook in mind – because we know only the finest cooking results, and nothing less, will do.

The Luce hob's Direct Flame technology gives you the widest possible heating area – producing perfectly even heat across the entire surface of the pan.

Because the technology delivers vertical heat straight to the pan via hundreds of tiny holes, you get a 20% saving in cooking time and energy*.

Our unique HD technologies are designed with the discerning cook in mind – because we know only the finest cooking results, and nothing less, will do.

75CM WIDE COOKTOPS PROVIDE A NEW DIMENSION WITH 25% MORE WORKING SPACE.

Whether planning from new or replacing your old cook top, there is now a hob choice with more workspace and more options. Some 75cm hobs will fit into a standard 60cm hob cut-out, so updating to more space, flexibility and burner power is simply a matter of specifying an Ariston 75cm hob.



PK755DGH



75cm Direct flame gas cooktop



- 5 Direct flame burners
- 20% faster and more energy efficient than standard burners
- Front controls
- Electronic ignition
- Flame failure safety gas shutoff device
- Dishwasher safe cast iron trivets and burners
- **Available in NG only. LPG due late 2013**

MADE IN ITALY

PK644DGH



60cm Direct flame gas cooktop



- 4 Direct flame burners
- 20% faster and more energy efficient than standard burners
- Easy to use diamond layout
- Front controls
- Electronic ignition
- Flame failure safety gas shutoff device
- Dishwasher safe cast iron trivets and burners
- **Available in NG only. LPG due late 2013**

MADE IN ITALY

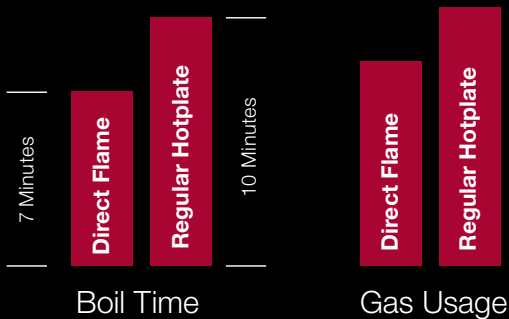

True to the inventive nature of Ariston, the new Direct Flame technology is set to revolutionise the gas hob market. By redesigning the standard burner, Ariston has produced a burner capable of faster cooking times, more direct use of flame all the while consuming less gas. Direct Flame technology will save you up to 20-30% gas and 30% time.

Gas has always been a favourite in the Australian kitchen now with the new one piece burner cap design, the Ariston Direct Flame burner is even easier to clean than the standard two piece burner. Simply put the cast enamel burners straight into the dishwasher.



PH 960 MST GH



90cm Gas Hob

- 6 gas burners
- 1 hand electronic ignition
- Flame failure gas cut-off system
- 4 cast iron grids

MADE IN ITALY

PK 750 RT GH



75cm Gas Hob

- 4 gas burners
- 1 hand electronic ignition
- Flame failure gas cut-off system
- 3 Cast Iron lift up grids for easy cleaning

MADE IN ITALY

PK640 RGH



60cm Experience Line Gas Hob

- 4 gas burners
- 1 hand electronic ignition
- Flame failure gas cut-off system
- 3 Cast Iron lift up grids for easy cleaning

MADE IN ITALY

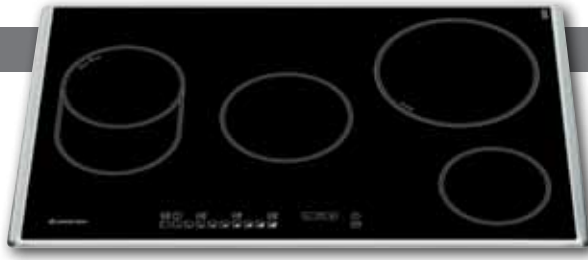

NIO 841 OX

80cm Ceramic Hob

- 4 radiant heat zones
- 9 power levels
- Touch control
- Residual heat indicators
- Child safety feature
- Stainless Steel frame



NRA640 C

60cm Ceramic Hob

- 4 radiant heat zones
- 9 power levels
- Touch control
- Residual heat indicators
- Child safety feature
- Frameless design



NRO 844 D OB



80cm Induction Hob

- 4 Induction Zones
- 9 Power levels
- Booster on two elements
- Touch control
- Time controlled heat zones
- Bevelled Edge



NIC 641 B



60cm Induction Hob

- 4 induction zones
- 9 power levels
- Booster
- Touch control
- Time controlled heat zones
- Bevelled Edge

Benefits of Induction Cooking

Instant Heating

Up to 30% faster than a gas burner: Ideal for large pots, allowing a minimum boiling time.

Precise

Accurate Temperature Control: From a simmer to a boil, and back again in an instant. Ideal cooking for those delicate sauces that require a consistent heat.

Energy Savings

90% more efficient: Induction requires less energy than any other hob, yet still performs more efficiently.

Safety

Low Surface Temperature: Minimising the chance of accidental burns, the cool touch surface of Induction is perfect for everyone.

Attractive

Easy to Clean: Thanks to the low surface temperatures there's no burnt on food to scrape off. Simply wipe away any mess with a damp cloth.



The Ariston exclusive 2x2 burner features a burner design that has two rings and two controls for the same burner. The outer ring and the inner burner can be controlled separately to give a range of heat and infinite control.



Ariston's unique Fast Cooking function will cook most meals 30-50% faster than a traditional Fan Forced mode. All oven elements are electronically interconnected to produce maximum oven heat and speed, while maintaining totally even heat distribution.



The Ariston Triple Ring (wok) burner is a very powerful burner - distributing heat evenly around the edge and centre of the pan. This provides the intense heat needed for quickly cooking with large frypans, woks or pasta pots.



CP 859 MTX



80cm Professional Upright Cooker

- 5 gas burners
- 1 hand electronic ignition
- Flame failure gas cut-off system
- 3 cast iron grids
- 8 electric cooking functions: Traditional, Multi-cooking, Barbeque, Gratin, Pizza, Baking, Grill (Rotisserie) & Defrosting
- Self-cleaning catalytic liners
- Integrated ventilation system
- 3 oven glass doors
- Electronic start / end cooking
- Rotisserie
- 90 Lt gross oven capacity

MADE IN ITALY



CP 059 MDX



90cm Professional Upright Cooker

- 5 gas burners
- 1 hand electronic ignition
- Flame failure gas cut-off system
- 3 cast iron grids
- 8 electric cooking functions: Traditional, Multi-cooking, Barbeque, Gratin, Pizza, Baking, Grill (Rotisserie) & Defrosting
- Self-cleaning catalytic liners
- Integrated ventilation system
- 3 Oven glass doors
- Electronic start / end cooking
- Rotisserie
- 90 Lt gross oven capacity

MADE IN ITALY



CX109SV6 AUS



• 100cm 4 Cavity Upright Cooker

- 6 gas burners
- 2 hand button ignition
- Flame failure gas cut-off system
- 3 cast iron grids
- Main Oven – 58L Fan Oven
- Second Oven – 58L Static Oven
- Grill Cavity
- Dish Warming Drawer
- Self-cleaning catalytic liners
- Integrated ventilation system
- Digital Timer
- Colours available: Anthracite or Cream



MADE IN ITALY



CX 65S M2X AUS



60cm Freestanding Oven

- 4 Burner Gas Hob
- Auto Ignition
- Flame Failure Safety Device
- 68 Lt gross oven capacity
- 5 Cooking Functions including: Grill, Gratin, Multi Level, Top Heat, Traditional
- Cast Iron Trivets
- Catalytic Liners
- 3 oven glass doors
- Storage Drawer
- Minute Minder



HKE 9 X

90cm Canopy Hood

- 90cm Stainless Steel Canopy
- Black Glass Fascia
- Electronic Touch Control
- 780m³/h Extraction
- 3 Speed Settings with Booster
- Timer
- 2 x Halogen Lights
- 3 Washable Aluminium Filters



HKB 9 LS X

90cm Box Canopy Hood

- 90cm Stainless Steel Canopy
- Black Glass Fascia
- Electronic Touch Control
- 780m³/h Extraction
- 3 Speed Settings with Booster
- Timer
- 2 x Halogen Lights
- 3 Washable Aluminium Filters





ARU52S/ ARU70S

52cm / 70cm Undermount Hood

- 500m³/h Extraction
- 55dB Noise rating
- 2 x Rear set halogen lights
- 3 Speed settings
- 150mm Ducting
- Push button control
- 1 x Aluminium filter
- White body with stainless Fascia



ARH6SIX/ ARH9SIX

60cm / 90cm Slide-out Rangehood

- 450m³/h Extraction
- 2 x Rear set halogen lights
- 2 Speed settings
- 120mm Ducting
- Mechanical control
- 1 x Aluminium filter
- White body with stainless Fascia

SL 16.1 P / SL 19.1 P

60cm / 90cm Slim Line Rangehood



- 460 m³/h Extraction
- Available in stainless steel or white
- 3 speed settings
- 2 X 20 W halogen lights
- 3 self-supporting aluminium filters for SL 19.1 P; 2 filters for SL 16.1 P.
- 120 mm Ducting
- Ducted or re-circulating installation



DISHWASHER DESIGN

The central philosophy of Makio Hasuike's design is a totally distinctive style. This is clearly evident in the new range of Ariston dishwashers - with simple, rounded shapes and distinctive features. The control panel, filters and the new basket design in particular with attention to the product design. Obtaining solid, innovative, functional appliances is an Ariston tradition.

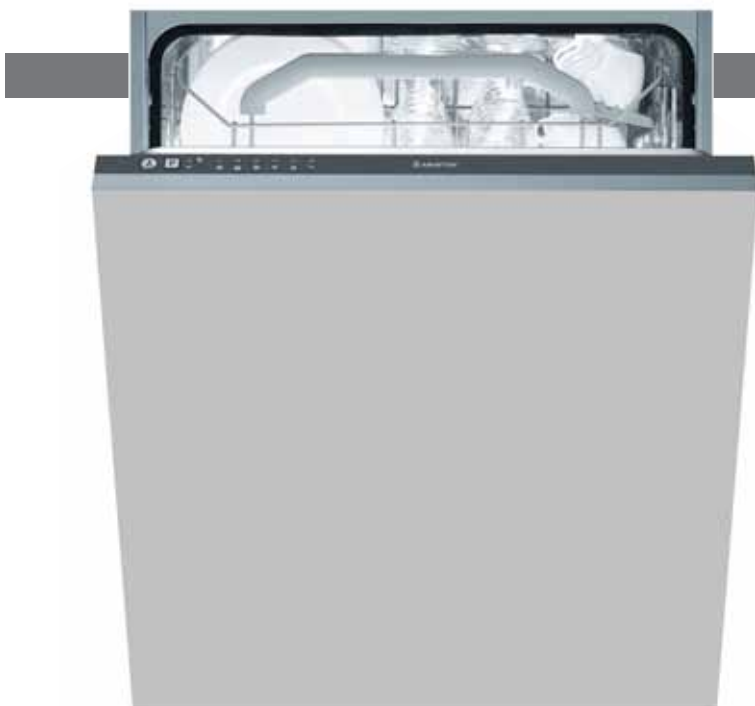

LFT216A

60cm Integrated dishwasher

- 14 place settings
- LED display
- 6 wash programs:
 - Soak
 - Eco Wash
 - Intensive
 - Normal
 - Rapid 35'
 - Delicate
- Sliding cutlery basket
- New telescopic guide system
- Concealed heating element
- Overflow safety device
- Stainless door panel available



LBF51 / X

60cm Freestanding dishwasher

- 14 place settings
- LED display
- 5 wash programs:
 - Soak
 - Eco Wash
 - Intensive
 - Normal
 - Rapid 35'
- Sliding cutlery basket
- New telescopic guide system
- Concealed heating element
- Overflow safety device
- Available in white or stainless steel



LFK720 / X

60cm Freestanding dishwasher

- 14 place settings
- LED display
- 7 wash programs:
 - Soak
 - Delicate
 - Eco Wash
 - Intensive
 - Normal
 - Daily 60'
 - Rapid 35'
- Options / Functions:
 - Multi-functional Tablets
 - Delay Start Timer
 - Half Load
- Sliding cutlery basket
- New telescopic guide system
- Concealed heating element
- New Aqua Stop – Anti-Flooding Protection in the event of a supply hose rupture.
- Available in white or stainless steel



Specifications

Steam Oven

Model	MSKA 103 X
Main cavity net capacity (l)	23
Finish	Stainless steel and black glass
Type of controls	Touch control
Cooking programming	Total electronic control
Oven on / off indicator	Yes
Door opening type	Drop down
Main oven type	Steam
Main oven functions	Defrost, Steam
Thermostat	Electronic
Cleaning	Manual
Lighting	1 on the top
Lighting	Automatic when opening door
Number of oven door glasses	2
Preselected temperatures	Yes
Main cavity material	Stainless steel
Oven guide type	Stainless steel guides
Accessories	1 grid, 1 tray, 1 perforated pan
Forced air	Yes
Supply voltage (V)	220-240V
Supply frequency (Hz)	50Hz
Absorbed power (W)	1000W
Absorbed current (A)	12A
Cable length (m)	1.25
Height (mm)	45.8
Width (mm)	59.5
Depth (mm)	54.5

Coffee Machine

Model	MCKA 103 X
Functions	Coffee, Hot Water, Steam
Coffee types	Long, Medium, Short
Coffee beans container (gm)	300gms
Water tank (L)	1.8L
Finish	Stainless steel and black glass
Interface	Electronic
Display color	Amber
Alerts	Yes - on display
Cleaning system	Semi-automatic
Kind of controls	Touch control
Low water signal	Yes
Low coffee bean signal	Yes
Waste tray full signal	Yes
Program of the coffee preparation	Electronic
Grind regulation	Yes
Double distribution	Yes
Distributor regulation	Yes
Coffee level regulation	Yes
Coffee temperature regulation	Yes
Coffee aroma regulation	Yes
Electronic control	Yes
Direct water connection	No
Supply voltage (V)	220-240 V
Supply frequency (Hz)	50/60 Hz
Absorbed power (W)	1350 W
Absorbed current (A)	6 A
Cable length (m)	2.0 m
Height (mm)	455 mm
Width (mm)	595 mm
Depth (mm)	413 mm

Microwaves

Model	MWKA 424 X	MWKA 221 X
Finish	Stainless steel and black glass	Black glass
Control types	Knobs and buttons	Knobs and buttons
Timer (min)	99	60
Digital clock	Yes	Yes
Grill on / off indicator	Yes	N/A
End of cooking signal	Yes	Yes
Cavity material	Enamel	Stainless steel
Cavity capacity (litres)	40	24
Oven lighting	1 x 25 W	1 x 25 W
Door opening type	Drop down	Side
Turntable diameter (mm)	360	30
No. power levels	10	5
Power levels (W)	1000, 125, 200, 300, 400, 500, 600, 700, 800, 900	150, 300, 450, 600, 750, 85, 900
Grill power levels	2	N/A
Movable grill	Yes	N/A
Cooking Ttypes	Grill, Microwave, Microwave+Grill, Microwave+Fan, Fan	Microwave
Oven functions	Drinks, Drinks, Pasta, Frozen Food, Precooked Food, Pizza, Fast Heating, Warm Plate, Defrost, Sequence Defrost, Cooking	Warm Plate, Defrost
Automatic cooking type	Based on weight	Based on weight
Accessories	1 plate, 1 enamelled tray	Medium round plate
Child safety	Yes	Yes
Supply voltage (V)	220-240 V	230-240 V
Supply frequency (Hz)	50 Hz	50 Hz
Absorbed power (W)	3400 W	1550 W
Absorbed current (A)	16 A	13 A
Cable length (m)	1.25 m	1.1 m
Output power (W)	1000 W	900 W
Ventilated oven power (W)	1600 W	N/A
Height (mm)	458 mm	368 mm
Width (mm)	592 mm	595 mm
Depth (mm)	545 mm	400 mm

Dishwashers

Model	LFT216X	LKF720 / X	LBF51 / X
Type	Fully integrated	Freestanding	Freestanding
Finish	N/A	Stainless or white	Stainless or white
Interface	LED	LED	LED
No. programs	6	6	5
No. place settings	14	14	14
Noise level (dB)	51	51	51
Cycles	Intense, Delicate, Daily, Eco, Soak, Rapid 35'	Intense, Daily, Eco, Soak, Delicate, Rapid 35'	Intense, Daily, Eco, Soak, Rapid 35'
Tab ready	No	Yes	No
Delay start	No	Yes	No
Half load	No	Yes	No
Wash cycle phase indicator	No	Yes	Yes
Drying type	Fan	Fan	Fan
Adjustable upper basket	Yes	Yes	Yes
Sliding cutlery basket	Yes	Yes	Yes
Concealed heating element	Yes	Yes	Yes
Fold down tines	Yes	Yes	Yes
Water supply	Hot or cold	Hot or cold	Hot or cold
Aqua stop	Yes	Yes	No
Supply voltage (V)	240 V	220-240V	220-240 V
Supply frequency (Hz)	50 Hz	50Hz	50 Hz
Absorbed current (A)	10 A	10 A	10 A
Water rating	3 Star	3 Star	3 Star
Water consumption	15.6L	15.6L	15.6L
Energy rating	2.5 Star	2.5 Star	2.5 Star
Energy consumption	386kW/h annually	386kW/h annually	386kW/h annually
Height (mm)	820 mm	850 mm	850 mm
Width (mm)	595 mm	600 mm	600 mm
Depth (mm)	570 mm	600 mm	600 mm

Model	FK 617 X AUS	FK 737 C X AUS	FK 898E P X AUS	OK 897EL C X AUS
Main cavity gross capacity (L)	68L	68L	68L	81L
Second cavity gross capacity (L)	N/A	N/A	N/A	N/A
Finish	Stainless steel	Stainless steel	Stainless steel and black glass	Stainless steel and black glass
Inner door	Full glass	Full glass	Full glass	Full glass
Type of controls	Knob	Knob + buttons	Knob + buttons	Electronic knobs + touch buttons
Function visualization	Graphics on the frontpanel	Graphics on the frontpanel	Display and pictograms	Display and pictograms
Cooking programming	Minute minder	Digital timer easy to use	Electronic display	Electronic display
Thermostat indicator	Yes	Yes	No	No
Oven on / off indicator	Oven light	Oven light	Oven light	Oven light
Main oven type	6 Multifunction	6 Multifunction	8 Multifunction	Multifunction 10
Main oven functions	Gratin, Grill, Multilevel, Pastries, Pizza, Traditional	Gratin, Grill, Multilevel, Pastries, Pizza, Traditional	Barbecue, Fast Cooking, Gratin, Multilevel, Pastries, Pizza, Defrosting, Traditional	Barbecue, Low Temperature, Cakes, Fast Cooking, Gratin, Beef, Multilevel, Bread, Pizza, Chicken
Second oven type	N/A	N/A	N/A	N/A
Second oven functions	N/A	N/A	N/A	N/A
Thermostat	Electromechanical	Electromechanical	Electronic	Electronic
Cleaning	Manual	Catalytic	Pyrolytic	Catalytic
Duration of pyrolysis cycles	N/A	N/A	Economic 60 Min, Intense 120 Min, Standard 90 Min	N/A
Recommended pyrolysis function and cycle duration	N/A	N/A	Yes	N/A
Turnspit	No	Yes	No	No
Lighting type	Normal	Normal	Halogen	Halogen
Light position	1 on the back	1 on the back	1 on the side	Door led
Lighting	On the knob	On the knob	Automatic when opening door	Automatic when opening door
Number of oven door glasses	2	2	3	3
Smoke chimney	Vented behind hob	Vented behind hob	Vented behind hob	Vented behind hob
Smoke purifier	No	No	Yes	Yes
Automatic cooking	No	No	Meat, Bread, Cake, Pizza	Meat, Bread, Cake, Pizza
Preselected temperature	No	No	Yes	Yes
Main cavity material	Enamel	Enamel	Grey enamel	Grey enamel
Oven guide type	Stainless steel guides	Stainless steel guides	Stainless steel guide and 1 level telescopic rail	Stainless steel guides
Main oven accessories rack, roasting tin"	1 tray, 2 grids 545 mm	1 tray, 2 grids 400 mm	1 tray, 1 deep tray, 2 grids	1 tray, 3 grids
Forced air	Yes	Yes	Yes	Yes
Door lock	No	No	Yes	No
Supply voltage (V)	220-240 V	220-240 V	220-240 A	220-240 V
Supply frequency (Hz)	50/60 Hz	50/60 Hz	50/60 Hz	50 Hz
Absorbed power (W)	3000 W	3000 W	2800 W	3400 W
Absorbed current (A)	12.5 A	12.5 A	12.1 A	14.8 A
Height (mm)	590 mm	590 mm	590 mm	595 mm
Width (mm)	595 mm	595 mm	595 mm	595 mm
Depth (mm)	570 mm	570 mm	570 mm	565 mm

Model	OS99DPIX	MB91X	DN62X
Main cavity gross capacity (L)	81L	90L	78L
Second cavity gross capacity (L)	20 / 48 (net)	N/A	37
Finish	Stainless steel	Stainless steel	Stainless steel
Inner door	Full glass	Full glass	Full glass
Type of controls	Electronic knobs + touch buttons	Knob + buttons	Knob + buttons
Function visualization	Display and pictograms	Graphics on the frontpanel	Graphics on the frontpanel
Cooking programming	Electronic display	Digital timer easy to use	Digital timer easy to use
Thermostat indicator	Yes	Yes	Yes
Oven on / off indicator	Oven light	Oven light	Oven light
Main oven type	Multifunction 10	Multifunction 7	Multifunction 6
Main oven functions	Grill, Low Temperature (3 options), Cakes, Meat, Multilevel, Gratin, Bread, Pizza	Traditional, Lower Heating Element, Upper Heating Element, Grill, Gratin, Pastries, Multilevel	Traditional, Fan Forced, Fan Assist, Fan Grill, Full Grill, Half Grill
Second oven type	2 (small) / 1 (medium)	N/A	Multifunction 2
Second oven functions	Grill, Fan (small) / Fan (medium)	N/A	Full Grill, Half Grill
Thermostat	Electronic		
Cleaning	Pyrolytic	Catalytic	Catalytic
Duration of pyrolysis cycles	Economic 60 Min, Intense 120 Min, Standard 90 Min	N/A	N/A
Recommended pyrolysis function and cycle duration	Yes	N/A	N/A
Turnspit	Yes	Yes	No
Lighting type	Halogen	Halogen	Halogen
Light position	2 on the side	1 on the side	1 on the side
Lighting	Automatic when opening door		
Number of oven door glasses	3	3	3
Smoke chimney	Vented behind hob	Vented behind hob	Vented behind hob
Smoke purifier	Yes		
Automatic cooking	Meat, Bread, Cake, Pizza	No	No
Preselected temperature	Yes	No	No
Main cavity material	Grey enamel		
Oven guide type	Stainless steel guides	Stainless steel guides	Stainless steel guides
Main oven accessories rack, roasting tin"	1 tray, 1 deep tray, 2 grids	1 tray, 2 grids	"1 x grid, kit grill pan, roasting
Forced air	Yes	Yes	Yes
Door lock	Yes	No	No
Supply voltage (V)	220-240 V	240 V	240 V
Supply frequency (Hz)	50 Hz	50 Hz	50 Hz
Absorbed power (W)	3400 W	3100 W	5100 W
Absorbed current (A)	14.8 A	13.4 A	21.25 A
Height (mm)	595 mm	895 mm	882 mm
Width (mm)	595 mm	480 mm	595 mm
Depth (mm)	545 mm	547 mm	550 mm

Specifications

Induction Hobs

Model	NIC641B	NIO 844 DO B AUS
Type	Induction	Induction
Finish	Black glass	Black glass
Edge	Bevelled	Bevelled
No. cooking zones	4	4
Control type	Touch control	Touch control
Location of controls	Front	Front
No. power levels	9	9
Timer	Yes	Yes
Pan detection	Yes	Yes
Boost function	Yes	Yes
On / off indicator	No	Yes - 4
Residual heat indicators	Yes - 4	Yes - 4
Child lock	Yes	Yes
Front left (W)	2200	Oval 2200 (Boost 3000)
Front right (W)	1400	1400 (Boost 2000)
Rear left (W)	1400	1400 (Boost 2000)
Rear right (W)	2200 (Boost 3000)	2200 (Boost 3000)
Supply voltage (V)	220-230 V	220-240 V
Supply frequency (Hz)	50 Hz	50 Hz
Absorbed power (W)	7200 W	7200 W
Absorbed current (A)	31.3 A	31.3 A
Height (mm)	53 mm	51 mm
Width (mm)	590 mm	785 mm
Depth (mm)	520 mm	520 mm

Ceramic Hobs

Model	NRA640C	NRO 841 DO B AUS
Type	Ceramic	Ceramic
Finish	Black glass	Black glass
Edge	Standard	Stainless frame
No. cooking zones	4	4
Control type	Touch control	Touch control
Location of controls	Front	Front
No. Power Levels	9	9
On / off indicator	Yes - 4	Yes - 4
Residual heat indicators	Yes - 4	Yes - 4
Child lock	Yes	Yes
Front left (W)	1200	-
Front right (W)	1800	1200
Middle left (W)	-	Oval 2400 / 1500
Middle (W)	-	1800
Rear left (W)	2300	-
Rear right (W)	1400	2300
Supply voltage (V)	220-240 V	220-230 V
Supply frequency (Hz)	50/60 Hz	50 Hz
Absorbed power (W)	6700 W	7700 W
Absorbed current (A)	29.1 A	33.4 A
Height (mm)	53 mm	53 mm
Width (mm)	590 mm	800 mm
Depth (mm)	520 mm	520 mm

Gas Hobs

Model	PK640TGH	PK750RGH	PH960MSTGH	PK644DGH	PK755DGH
Aesthetics	Luce	Luce	Standard	Luce	Luce
Knob colour	Black and inox	Black and inox	Silver	Black and inox	Black and inox
Burner cap	Enamelled	Cast iron	Cast iron	N/A	N/A
Location of control panel	Front	Front	Front	Front	Front
Electronic ignition	Yes	Yes	Yes	Yes	Yes
Flame failure device	Yes	Yes	Yes	Yes	Yes
No. pan supports	2	3	4	4	3
Pan support type	Cast iron	Cast iron	Cast iron	Cast iron	Cast iron
No. gas burners	4	4	6	4	5
Left rear area-type	-	-	Semi Fast	-	Semi Fast
Left rear area-dimensions	-	-	75 mm	-	132 mm
Left rear area-power (MJ/h)	-	-	6	-	1900W
Middle rear area-type	Auxiliary	Semi Fast	-	Semi Fast	-
Middle rear area-dimensions	55 mm	75 mm	-	132 mm	-
Middle rear area-power (MJ/h)	3.6	6	-	1900W	-
Right rear area-type	-	-	Auxiliary	-	Semi Fast
Right rear area-dimensions	-	-	55 mm	-	132 mm
Right rear area-power (MJ/h)	-	-	3.3	-	1900W
Left middle area-type	Fast	Double Ring Double Regulation	Triple Ring	Semi Fast	-
Left middle area-dimensions	100 mm	130 mm	130 mm	132 mm	-
Left middle area-power (MJ/h)	7.8	17	15	1900W	-
Middle area-type	-	-	-	-	Fast
Middle area-dimensions	-	-	-	-	157 mm
Middle area-power (MJ/h)	-	-	-	-	3000W
Right middle area-type	Double Ring Double Regulation	Triple Ring	Fast	Fast	-
Right middle area-dimensions	130 mm	130 mm	100 mm	157 mm	-
Right middle area-power (MJ/h)	13	13.5	9	3000W	-
Left front area-type	-	-	Double Face	-	Auxiliary
Left front area-dimensions	-	-	92 X 62 mm	-	110 mm
Left front area-power (MJ/h)	-	-	5	-	1000W
Middle front area-type	Semi Fast	Auxiliary	-	Auxiliary	-
Middle front area-dimensions	75 mm	55 mm	-	110 mm	-
Middle front area-power (MJ/h)	6	3.6	-	1000W	-
Right front area-type	-	-	Double Face	-	Auxiliary
Right front area-dimensions	-	-	92 X 62 mm	-	110 mm
Right front area-power (MJ/h)	-	-	5	-	1000W
Supply voltage (V)	220-240 V	220-240V	23-240V	220-240	220-240
Supply frequency (Hz)	50/60 Hz	50/60	50/60Hz	50/60	50/60
Gas power (kW)	8.85 kW	11.25	11.5	-	8.8
Fuses	Mono 230 V - 6 A	Mono 230 V - 6 A	Mono 230 V - 6 A	Mono 230 V - 6 A	Mono 230 V - 6 A
Gas type	NG or LPG	NG or LPG	NG or LPG	NG ONLY	NG ONLY
Height (mm)	43.9 mm	33 mm	33 mm	40 mm	40 mm
Width (mm)	650 mm	75 mm	870 mm	600 mm	750 mm
Depth (mm)	510 mm	51 mm	510 mm	520 mm	520 mm

Upright Cookers

Model	CX65SM2X	CP859MTX	CP059MDX	CX109SV6X A/C
MAIN OVEN				
Main oven gross capacity (L)	64L	78L	78L	57L
Main oven location	N/A	N/A	N/A	Lower left
Main oven type	Multifunction 5	Multifunction 8	Multifunction 8	Fan
Main oven functions	Grill, Gratin, Multi Level, Pizza, Traditional	Traditional, Multi Level, Barbeque, Gratin, Pizza, Baking, Grill, Defrost	Traditional, Multi Level, Barbeque, Gratin, Pizza, Baking, Grill, Defrost	Fan
No. of main oven door glasses	3	3	3	2
Type of main oven guides	Stainless steel guides	Stainless steel guides	Stainless steel guides	Stainless steel guides
SECONDARY OVEN				
Secondary oven net capacity (L)	N/A	N/A	N/A	57L
Secondary oven location	N/A	N/A	N/A	Upper right
Secondary oven type	N/A	N/A	N/A	Static
Secondary oven functions	N/A	N/A	N/A	Static
Secondary oven temperature control	N/A	N/A	N/A	Thermostat
Secondary oven cleaning	N/A	N/A	N/A	Catalytic liners
No. of secondary oven door glasses	N/A	N/A	N/A	2
Type of oven guides	N/A	N/A	N/A	Stainless steel guides
HOB				
Fascia colour	Stainless steel	Stainless steel	Stainless steel	Black
Knob colour	Stainless steel	Stainless steel	Stainless steel	Metallic
Warming draw	No	No	No	Yes
Storage draw	Yes	No	No	No
Type of regulation	Knobs	Knobs	Knobs	Knobs
Cooking programming	Minute minder	Electronic timer	Electronic timer	Electronic timer
Function indicator	Graphics on front panel	Graphics on front panel	Graphics on front panel	Graphics on front panel
Thermostat indicator	Yes	Yes	Yes	Yes
Rotisserie	No	Yes	Yes	No
Hob ignition	Automatic	Automatic	Automatic	Button 2 hands
Pan support type	Cast iron	Cast iron	Cast iron	Cast iron
No. of hob pan supports	2	3	3	3
Burner cap	Cast iron	Cast iron	Cast iron	Enamelled
Griddle plate	No	No	No	Yes
No. gas burners	5	5	5	6
Rear left area-type	Semi Fast		Semi Fast	Fast
Rear left area-dimensions	75 mm	75 mm	75 mm	100 mm
Rear left area-power (W)	1900W	1650W	1650W	3000
Middle rear area-type				Auxiliary
Middle rear area-dimensions				55 mm
Middle rear area-power (W)				1000
Rear right area-type	Fast	Auxiliary	Auxiliary	Double Face
Rear right area-dimensions	100 mm	55 mm	55 mm	92X62 mm
Rear right area-power (W)	3000W	1000W	1000W	1500
Front left area-type	Triple Ring	Semi Fast	Semi Fast	Semi Fast
Front left area-dimensions	130 mm	75 mm	75 mm	75 mm
Front left area-power (W)	3250W	1650W	1650W	1900
Middle area-type		Triple Ring	Double Ring Double Regulator	
Middle area-dimensions		130 mm	130 mm	
Middle area-power (W)		3250W	900W + 4100W	
Middle front area-type				Double Ring Double Regulation
Middle front area-dimensions				130 mm
Middle front area-power (W)				4100 + 900
Front right area-type	Auxiliary	Fast	Fast	Double Face
Front right area-dimensions	55 mm	100 mm	100 mm	92X62 mm
Front right area-power (W)	1000W	3000W	3000W	1500
Temperature control	Thermostat	Thermostat	Thermostat	Thermostat
Cleaning	Catalytic liners	Catalytic liners	Catalytic liners	Catalytic liners
Hob flame failure device	Yes	Yes	Yes	Yes
Cooling fan	Yes	Yes	Yes	Yes
Supply voltage (V)	240 V	230-240 V	230-240 V	230-240 V
Supply frequency (Hz)	50/60 Hz	50 Hz	50 Hz	50 Hz
Absorbed power (W)	3000 W	3850-3105 W	3850-3105 W	8500-9200 W
Absorbed current (A)	12.5 A	12.39 A	12.39 A	35-38 A
Gas power (kW)	7.8 kW	10.55 kW	12.3 kW	13.9 kW
Gas type	NG or LPG	NP or LPG	NP or LPG	NG or LPG
Height (mm)	900 mm	850 ~ 910 mm	850 ~ 910 mm	900 mm
Width (mm)	600 mm	900 mm	900 mm	1000 mm
Depth (mm)	600 mm	600 mm	600 mm	600 mm

Specifications

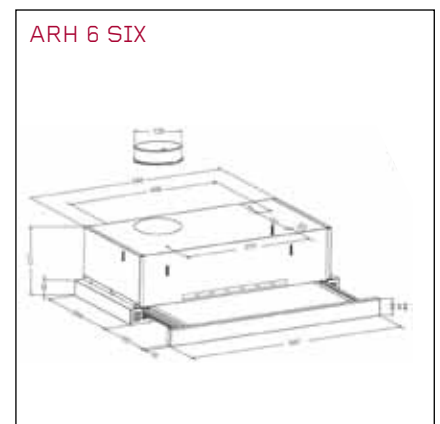
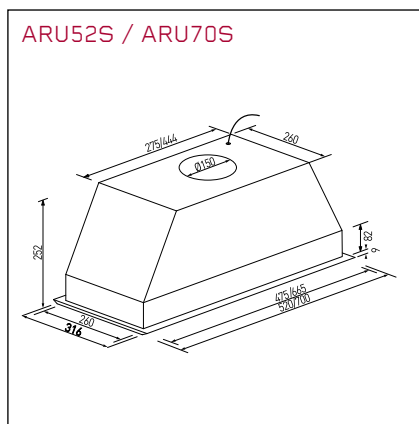
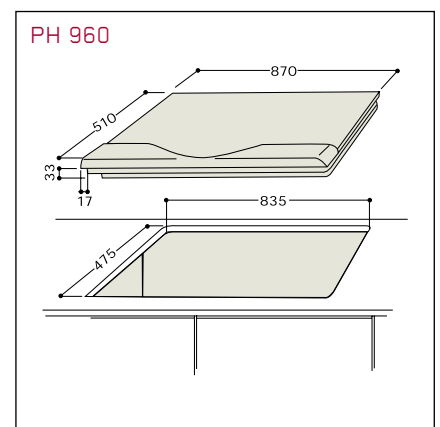
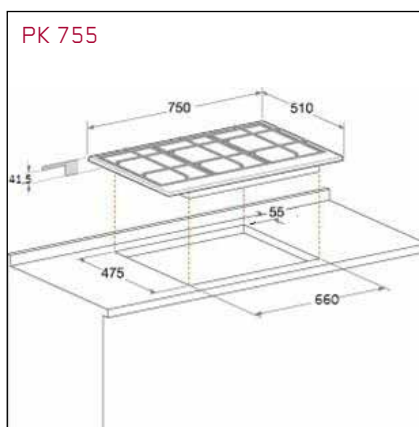
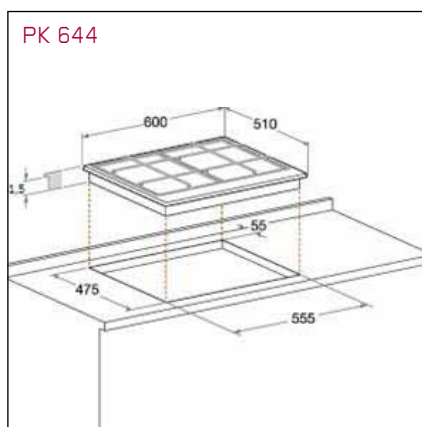
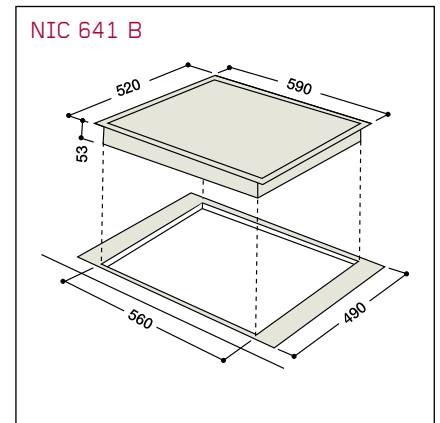
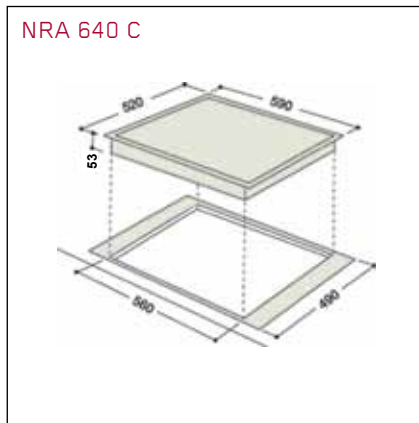
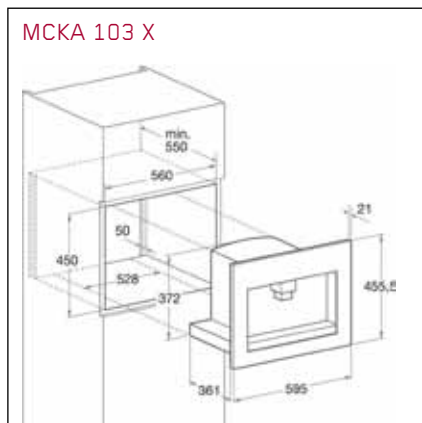
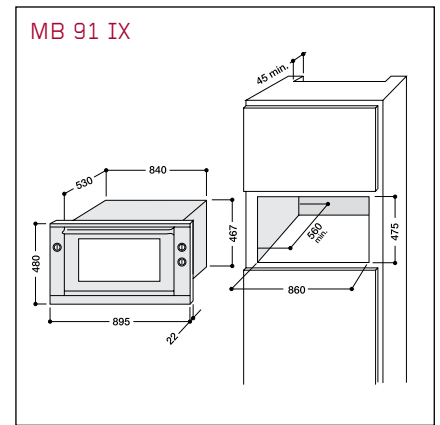
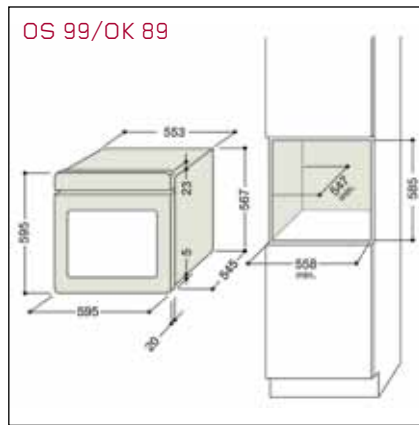
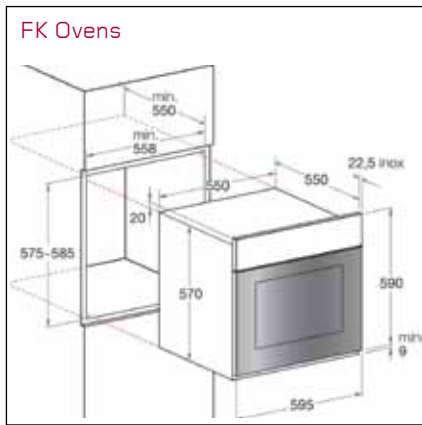

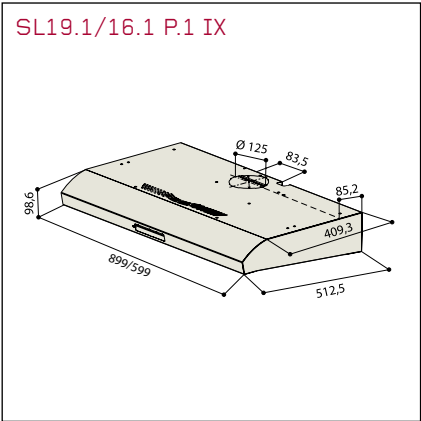
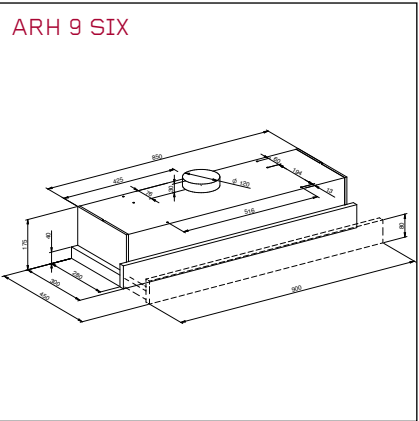
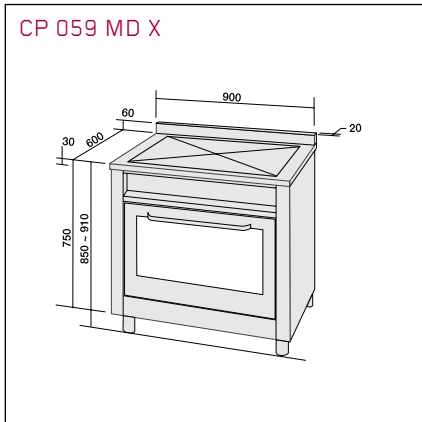
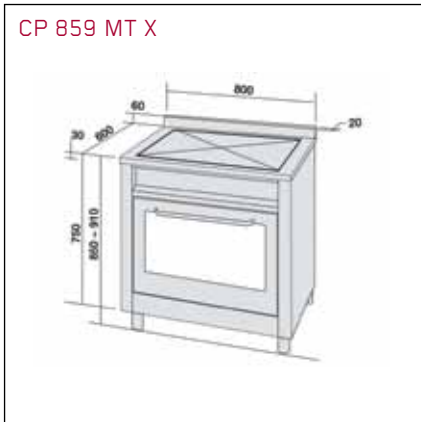
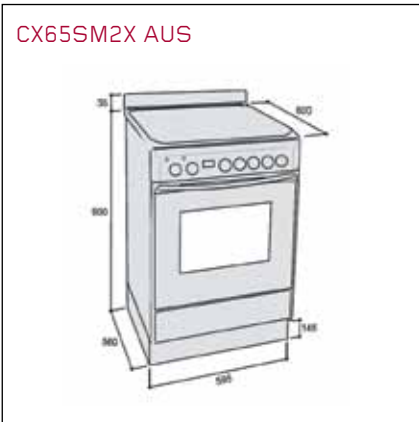
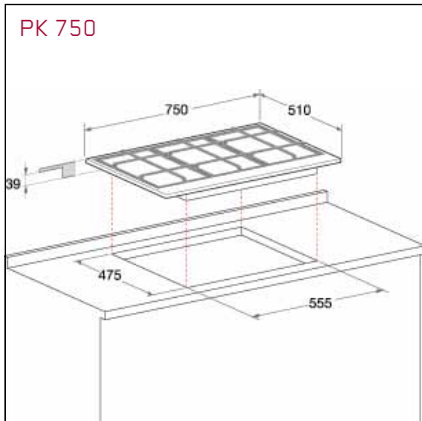
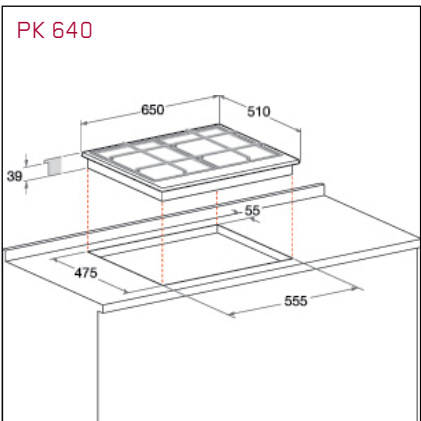
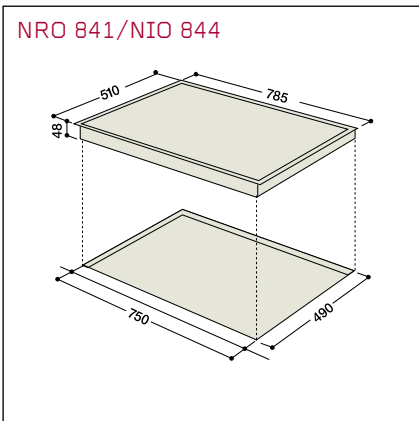
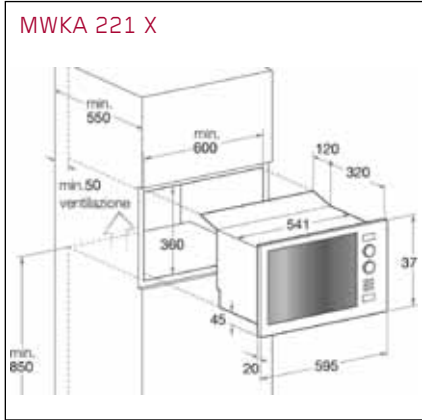
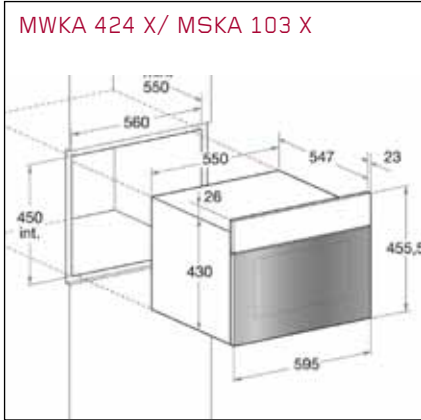
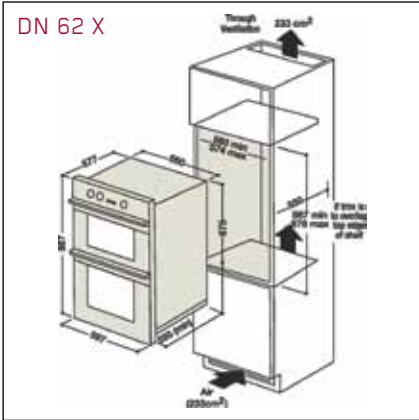

Arisit Pty Limited are not responsible for any errors or omissions. Pictures, specifications and dimensions are for illustration purposes only and are subject to change without notice.



ARISTON

OUR IDEAS. YOUR HOME.

Cooking Collection



ARISIT PTY LIMITED (Australia)

ABN 23 091 515 294
40-44 Mark Anthony Drive
Dandenong South VIC 3175

P: Sales: 1300 762 219 - Service: 1300 815 589

F: Sales & Service (03) 9768 0838

E: arisit@arisit.com

W: www.arisit.com

ARISIT PTY LIMITED (New Zealand)

1A Howe Street Newton, Auckland 1145
PO Box 68-140 Newton, Auckland 1145

P: (09) 306 1020 - Fax: (09) 302 0077

E: sales@aristonappliances.co.nz

W: www.arisit.com

ALL ARISTON COOKING PRODUCTS CARRY A
"TOTAL PEACE OF MIND" 5 YEAR WARRANTY